



**INVITATION FOR SUBMISSION OF BIDS FOR THE SUPPLY OF
CUTLERY FOR BUSINESS CLASS & ECONOMY CLASS USE**

REFERENCE NO: IF/EPC/02/2026

**CHAIRMAN OF ENTERPRISE PROCUREMENT COMMITTEE,
MINISTRY OF PORTS AND CIVIL AVIAITION**

ON BEHALF OF

**SRILANKAN AIRLINES
COMMERCIAL PROCUREMENT DEPARTMENT (INFLIGHT PROCUREMENT)
AIRLINE CENTRE
BANDARANAYAKE INTERNATIONAL AIRPORT
KATUNAYAKE
SRI LANKA**

Section I. Instructions to Bidder (ITB)

A: General	
1. Scope of Bid	<p>1.1 SriLankan Airlines invites you to submit a bid for the supply of cutlery for Business Class service as specified in Section III - Schedule of Requirements.</p> <p>You are requested to confirm your intention to submit a bid by forwarding the duly filled Bid Acknowledgement Form attached, 07 working days prior to bid closing date.</p>
B: Contents of Documents	
2. Contents of Documents	<p>2.1 The documents consist of the Sections indicated below:</p> <ul style="list-style-type: none">• Section I. Instructions to Bidders• Section II. Data Sheet• Section III. Schedule of Requirements• Sections IV. Bid Submission Form• Section V. General Conditions• Annexure A: Bid Acknowledgement Form• Annexure B: Technical/General Specifications & Compliance form• Annexure C: Price Schedule Form• Annexure D: Bid Securing Declaration Form• Annexure E: Performance Bond• Annexure F: Non collusion Declaration• Annexure G: Clientele Information Form• Annexure H: Sample Contract• Annexure I: Vendor Information Form

	C: Preparation of Bid
3. Documents Comprising your Bid	<p>3.1 The document shall comprise the following: The document shall comprise the following:</p> <ul style="list-style-type: none"> • Sections IV: Bid Submission Form (Mandatory- two separate forms are available for BC and EY. Submit both forms only if you are bidding for both BC and EY cutlery) • Annexure B: Technical/General Specifications & Compliance Form (Mandatory) • Annexure C: Price Schedule Form (Mandatory) • Annexure D: Bid Securing Declaration Form (Mandatory) • Annexure F: Non collusion Declaration (Mandatory) • Annexure G: Clientele Information Form • Annexure I: Vendor Information Form
4. Bid Submission Form and Technical/General Specifications & Compliance form	<p>4.1 The Bidder shall submit the Bid Submission Form using the form furnished in Section IV. This form must be completed without any alterations to its format, and no substitutes shall be accepted. All blank spaces shall be filled in with the information requested.</p>
5. Prices	<p>5.1 Unless stated in Data Sheet, all items must be priced separately in the Price Schedule Form.</p> <p>5.2 The price to be quoted in the Bid Submission Form shall be the unit price of the Bid.</p> <p>5.3 Prices quoted by the Bidder shall be fixed during the period specified in ITB clause 8.1 and not subject to variation on any account. A Bid submitted with an adjustable price shall be treated as non-responsive and may be rejected.</p>
6. Currency	<p>6.1 The Bidders shall quote in foreign currency or in Sri Lanka Rupees.</p>
7. Documents to Establish Conformity of the Goods	<p>7.1 The Bidder shall submit following documents along with the bid for evaluation:</p> <ul style="list-style-type: none"> - Technical drawings - Material details
8. Period of Validity of bid	<p>8.1 Bids shall remain valid for a period of 120 days after the bid submission deadline date.</p>

9. Bid Securing Declaration	9.1 The Bidder shall furnish as part of its bid, a Bid Securing Declaration, using Form included in Annexure D.
10. Format and Signing of Bid	10.1 The bid shall be typed or written in ink and shall be signed by a person duly authorized to sign on behalf of the Bidder. Please ensure all documents are duly signed and stamped in the given area when forwarding.
D: Submission of Samples	
11. Submission of Samples	<p>11.1 Please forward 02 samples for each proposed cutlery item</p> <p>11.2 Samples should be clearly referenced, and same references should be mentioned in bids.</p> <p>11.3 If a sample is submitted for quality reference, clearly mention ‘only for quality reference’ on the sample and confirm the ability of customizing according to SriLankan Airlines’ specifications in the bid.</p> <p>11.4 Bids without proper samples for evaluation will be subject to rejection.</p> <p>11.5 It is advised to forward the bids and samples separately to avoid any delays in receiving the bid on time for the public opening. Bidders will have a maximum period of three weeks from the bid closing date to submit samples. Any samples submitted after this three-week period will be rejected and will not be considered for evaluation.</p> <p>11.6 If any bidder wishes to hand deliver samples, please contact SriLankan Airlines staff well in advance, for the arrangement of security clearance. Refer Section 11, Data sheet, clause 16.2 for contact details.</p>
E: Submission and Opening of Bid	
12. Submission of Bid	<p>12.1 Bidders shall submit their bids by registered post, courier or by hand in a sealed envelope to the address set out in Section II Data Sheet</p> <p>12.2 The sealed envelope shall bear the specific identification of this bid exercise as indicated follows: “Supply of Cutlery for Business Class and economy class Use-IF/EPC/02/2026”</p> <p>12.3 It is advised to forward the bids and samples separately to avoid any delays in receiving the bid on time for the public opening.</p> <p>12.4 If any bidder wishes to hand deliver the bids, please contact SriLankan Airlines staff well in advance, for the arrangement of security clearance. Refer Section 11, Data sheet, clause 16.2 for contact details.</p>
13. Deadline for Submission of Bid	13.1 Bid must be received by the SriLankan Airlines to the address set out in Section II, “Data Sheet”, and no later than the date and time as specified in the Data Sheet.
14. Late Bid	14.1 SriLankan Airlines shall reject any bid that arrives after the deadline for submission of bids in accordance with ITB Clause 12.1 above.

<p>15. Opening of Bids</p>	<p>15.1 SriLankan Airlines shall conduct the opening of bids in the presence of the Bidders at the address, date and time specified in the Data Sheet.</p> <p>15.2 A representative of the bidders may be present and mark its attendance</p> <p>15.3 If any bidder wishes to participate in the bid opening, please contact SriLankan Airlines staff well in advance for the arrangement of security clearance. Refer Section 11, Data sheet, clause 16.2 for contact details</p> <p>15.4 Presence of the Bidder will not necessarily ensure selection of the proposed goods.</p>
<p>F: Evaluation and Comparison of Bid</p>	
<p>16. Clarifications</p>	<p>16.1 To assist in the examination, evaluation and comparison of the bids, SriLankan Airlines may, at its discretion, ask any Bidder for a clarification of its bid. Any clarification submitted by a Bidder in respect to its bid which is not in response to a request by the SriLankan Airlines shall not be considered.</p> <p>16.2 SriLankan Airlines' request for clarification and the response shall be in writing at SriLankan Airlines' email address specified in the Data Sheet.</p>
<p>17. Responsiveness of Bids</p>	<p>17.1 SriLankan Airlines will determine the responsiveness of the bid to the documents based on the contents of the bid received.</p> <p>17.2 If a bid is evaluated as not substantially responsive to the documents issued, it may be rejected by the SriLankan Airlines.</p>
<p>18. Evaluation of bid</p>	<p>18.1 The items will be subjected to a technical evaluation based on the following criteria:</p> <ul style="list-style-type: none"> I. Compliance for technical and general specifications in Annexure B (all 04 items will be evaluated as a set) II. Clientele and client feedback III. SriLankan Airlines' past experience with the bidders IV. Total cost and credit terms
<p>19. SriLankan Airlines' Right to accept any Bid, and to reject any or all Bids.</p>	<p>19.1 SriLankan Airlines reserves the right to accept or reject any bid, and to annul the process and reject all bids at any time prior to acceptance, without thereby incurring any liability to bidders.</p>

G: Award of Contract	
20. Acceptance of the Bid	20.1 SriLankan Airlines will accept the bid of the Bidder whose offer is not necessarily the lowest evaluated bid and is substantially responsive to the documents issued.
21. Notification of acceptance	<p>21.1 SriLankan Airlines will notify the successful Bidder, in writing, that their bid has been accepted.</p> <p>21.2 After notification, SriLankan Airlines shall complete the contract, and inform the successful Bidder to sign it.</p> <p>21.3 Within seven (7) days of receipt of such information, the successful Bidder shall sign the contract.</p>
22. Performance Bond	<p>22.1 Within fourteen (14) days of the receipt of notification of award from the SriLankan Airlines, the successful Bidder shall furnish the performance security of 10% of the total value of the contract, using the Performance Security Form included in Annexure E.</p> <p>22.2 The performance security shall be an unconditional, irrevocable, on demand bank guarantee drawn at sight in favor of the SriLankan Airlines valid for the period of contract and 90 days thereafter.</p> <p>22.3 Failure of the successful Bidder to submit the above mentioned performance security or sign the contract shall constitute sufficient grounds for the annulment of the award and forfeiture of the Bid Security. In the event SriLankan Airlines may award the contract to the next lowest evaluated bidder, whose offer is substantially responsive and is determined by SriLankan Airlines to be qualified to perform the contract satisfactorily.</p>

Section II: Data Sheet

ITB Clause Reference	
12.1	<p>The address for submission of Bids and samples is: Attention: Senior Manager Commercial Procurement Address: Commercial Procurement Department, Airline Centre, Bandaranaike International Airport, Katunayake, Sri Lanka</p> <p>Details should be provided one day in advance to arrange security clearance if the bidder wishes to hand deliver bids and samples.</p>
13.1	<p>Deadline for submission of bids is on or before 28 April 2026, 1000, hrs. SriLankan Time (GMT +5:30)</p> <p>Details should be provided one day in advance to arrange security clearance if the bidder wishes to hand deliver bids and samples.</p>
15.1	<p>Opening of bids on 28 April 2026, 1030 hrs SriLankan Time (GMT +5:30)</p> <p>Details should be provided one day in advance to arrange security clearance if the bidder wishes to participate in the bid opening.</p>
16.2	<p><u>For Clarification/ handing over bids and samples/participating for bid opening:</u></p> <p>Telephone: +94 (0) 19733 2648/ 2771</p> <p>E mail address: wiranga.perera@srilankan.com srimal.kamalpriya@srilankan.com</p> <p>Details should be provided one day in advance to arrange security clearance if the bidder wishes to hand deliver bids/ samples /participate for bid opening.</p>

Section III - Schedule of Requirements

Business class Cutlery

Line Item #	Description of Goods	Estimated quantity for 05 years	Unit of Measurement	Final Destination	Delivery Date
1	Dessert Fork	144,000	Each	Bulk Stores, Katunayake, Sri Lanka	As per SLA requirement
2	Dessert Spoon	66,000	Each	Bulk Stores, Katunayake, Sri Lanka	As per SLA requirement
3	Teaspoon	54,000	Each	Bulk Stores, Katunayake, Sri Lanka	As per SLA requirement
4	Table Knife	144,000	Each	Bulk Stores, Katunayake, Sri Lanka	As per SLA requirement

** Please note that the quantities are estimated quantities and would differ depending on passenger loads, flight frequency, destination changes, etc

Section III - Schedule of Requirements

Economy class Cutlery

Line Item #	Description of Goods	Estimated quantity for 05 years	Unit of Measurement	Final Destination	Delivery Date
1	EY Fork	660,000	Each	Bulk Stores, Katunayake, Sri Lanka	As per SLA requirement
2	EY Knife	840,000	Each	Bulk Stores, Katunayake, Sri Lanka	As per SLA requirement
3	EY Dessert Spoon	660,000	Each	Bulk Stores, Katunayake, Sri Lanka	As per SLA requirement

** Please note that the quantities are estimated quantities and would differ depending on passenger loads, flight frequency, destination changes, etc

THIS IS A COMPULSORY FORM. IF THIS FORM IS NOT FILLED AND SUBMITTED, THE BID SHALL BE REJECTED.

Section IV - Bid Submission Form- BC Cutlery

[The Bidder shall fill in this Form in accordance with the instructions indicated no alterations to its format shall be permitted and no substitutions will be accepted.]

Date:

To: SriLankan Airlines

We, the undersigned, declare that:

- (a) We have read and have no reservations to the document issued;
- (b) We agree to supply conforming to the documents issued and in accordance with the Schedule of Requirements of Supply of Cutlery for Business Class Service;
- (c) The unit prices of our bid is (For local bidders only - including NBT and excluding VAT): [insert the individual unit price in words and figures];
 - i. Dessert Fork
 - ii. Dessert Spoon
 - iii. Teaspoon
 - iv. Table Knife
- (d) Our bid shall be valid for the time specified in ITB Clause 8.1
- (e) We understand that our bid, together with your written acceptance thereof included in your notification of award, shall constitute a binding contract between us.
- (f) We understand that you are not bound to accept the lowest evaluated bid or any other bid that you may receive.
- (g) Bid Securing Declaration is attached and same is valid for a period of 120 days after the bid submission deadline date.

Signed:

Name:

Date

THIS IS A COMPULSORY FORM. IF THIS FORM IS NOT FILLED AND SUBMITTED, THE BID SHALL BE REJECTED.

Section IV - Bid Submission Form - EY Cutlery

[The Bidder shall fill in this Form in accordance with the instructions indicated no alterations to its format shall be permitted and no substitutions will be accepted.]

Date:

To: SriLankan Airlines

We, the undersigned, declare that:

- (a) We have read and have no reservations to the document issued;
- (b) We agree to supply conforming to the documents issued and in accordance with the Schedule of Requirements of Supply of Cutlery for Business Class Service;
- (c) The unit prices of our bid is (For local bidders only - including NBT and excluding VAT): [insert the individual unit price in words and figures];
 - i. EY Fork
 - ii. EY Knife
 - iii. EY Dessert Spoon
- (d) Our bid shall be valid for the time specified in ITB Clause 8.1
- (e) We understand that our bid, together with your written acceptance thereof included in your notification of award, shall constitute a binding contract between us.
- (f) We understand that you are not bound to accept the lowest evaluated bid or any other bid that you may receive.
- (g) Bid Securing Declaration is attached and same is valid for a period of 120 days after the bid submission deadline date.

Signed:

Name:

Date

Section V - General Conditions

- I. If the bid is accepted, it is mandatory that the Bidder signs the Contract with SLA.
- II. SriLankan Airlines would carry out unannounced factory inspections during evaluation stage and during the contract period if deemed necessary and applicable
- III. In order to ensure continuity of supply of goods/Services to SriLankan Airlines in the event of a disruption to bidder's operations, please provide details of alternative arrangements available within the agreed cost and specifications of product.
- IV. If the delivered goods are not in accordance with all agreed specifications with SriLankan Airlines, then SriLankan Airlines reserves the right to reject such goods and recover all monies paid.
- V. Please state whether your company has appointed a local agent for SriLankan Airlines (applicable only for foreign bidders), for supply & delivery of cutlery for Business Class service specified in this bid exercise. If so please submit a separate bidder information form including the information of local agent.
- VI. Liquidated Damages
 - a. Liquidated damages shall be applied for late deliveries.
 - b. Liquidated damages shall be determined by SriLankan Airlines and shall in any event be not less than the higher of (a) rate of one percent (01%) of the amount due for delivery per day (b) LKR 10,000 per day.

ANNEXURE A: BID ACKNOWLEDGEMENT FORM
IMPORTANT

All Bidders shall confirm their intention to submit a Bid by forwarding the duly filled Bid Acknowledgement Form, 07 working days prior to the Bid closing date to the following email address.

.....
 Invitation for Submission of Bids for
 Reference No - .../.... is hereby acknowledged.

may expect to receive our proposal on or before.

.....

We do not intend to submit a proposal because.

.....

Item	Details
Name of Bidder	[Insert Full Legal Name]
Address	[Insert Mailing Address]
Contact Person	[Insert Name and Designation]
Telephone Number	[Insert Phone Number]
Email Address	[Insert Email Address]

We understand that by acknowledging receipt, we will be informed of any amendments, clarifications, or addenda issued by the Procurement Entity.

Signed:
 Designation :
 Company :
 Date :



Note: SriLankan Airlines will not be responsible for sharing any amendments, clarifications, or addenda issued later with regard to the tender with those bidders who have not submitted this form.

THIS IS A COMPULSORY FORM. IF THIS FORM IS NOT FILLED AND SUBMITTED, THE BID SHALL BE REJECTED.

ANNEXURE B - Technical/General Specifications & Compliance form (BC Cutlery)

Name of the Bidder :

Running Number	Technical Specifications (Mandatory)	Bidder's Response (Yes/No)	Remarks
1.	<p>Measurements \pm 0.3cm</p> <p>1 Dessert Fork</p>  <p>2. Dessert Spoon</p>		

Running Number	Technical Specifications (Mandatory)	Bidder's Response (Yes/No)	Remarks
	 <p data-bbox="472 772 629 802">3. Tea Spoon</p>  <p data-bbox="472 1329 640 1359">4. Table Knife</p>		

Running Number	Technical Specifications (Mandatory)	Bidder's Response (Yes/No)	Remarks
	 <p>The blade should be serrated.</p> <p>Mention the measurements of the proposed cutlery on the remarks column</p> <p>Any reference mentioned in the bid for each cutlery option should be clearly marked on the samples for easy identification of samples.</p>		
2	<p>Design Guidelines</p> <p>Angled 'cut-off' corners and clean styling.</p> <p>Double bevelled edges.</p> <p>In addition to the present SriLankan Airlines design shown above, 02 similar designs could be proposed. (However, preference will be for present SriLankan Airlines design)</p> <p>All 4 items should complement each other in design as a set.</p>		

Running Number	Technical Specifications (Mandatory)	Bidder's Response (Yes/No)	Remarks
			
3	<p>Material</p> <p>18/10 stainless steel conforming to British Standards ISO 8442, F.D.A. and US Public health regulations and European Health Directive.</p>		
4	<p>Branding</p> <p>SriLankan bird logo to be etched marked or embossed on the top side of the handle.</p>		

Running Number	Technical Specifications (Mandatory)	Bidder's Response (Yes/No)	Remarks
	 Please specify the method of branding in remarks column		
5	Product Quality Durable, elegant and well balanced for use in Business Class		
6	Polishing method Mirror-polish		
7	Warranty Lifetime warranty for corrosion, discolouration and etching/embossing		

Running Number	General Specifications (Mandatory)	Bidder's Response (Yes/ No)	Remarks
1.	Delivery Minimum 04 deliveries per annum		
2.	Packing Individually packed in poly bag X inner box X carton X wooden crates Each cutlery item to be individually packed in a poly bag (above 20 microns) Wooden crates palletized and shrink wrapped. For information: Please mention the number of cutlery items in the inner box Please mention the number of inner boxes per carton Please mention the number of cartons per wooden crate		

Running Number	General Specifications (Mandatory)	Bidder's Response (Yes/ No)	Remarks
3.	<p>Payment Terms</p> <p>A minimum credit period of 30 days (from the date received) is required for all invoices, covering 100% of the payment.</p>		
4.	<p>Termination clause</p> <p>The contract shall be awarded for a period of five (5) years. However, the Purchaser reserves the right to amend, reduce, or terminate the contract period in the event of persistent quality issues or recurrent delays in supply or service delivery. Such action may be taken at the sole discretion of the Purchaser, based on documented performance concerns, with a thirty (30) day notice period for termination.</p>		
5.	<p>Agreeable to provide the Performance Bond</p> <p>10% of the total contract value</p>		

Running Number	General Specifications (Non-Mandatory)	Bidder's Response (Yes/ No)	Remarks
1	<p>Carton Marking</p> <p>Item code, quantity per carton to be printed on each carton.</p>		

THIS IS A COMPULSORY FORM. IF THIS FORM IS NOT FILLED AND SUBMITTED, THE BID SHALL BE REJECTED.

ANNEXURE C: Price Schedule Form (BC Cutlery)

Name of the Bidder (Commercial and the Registered name) :

Name of the Principal/ Manufacturer (Commercial and the Registered name) :

Line Item N°	Description of Goods	Country of Origin/ manufacture	Estimated Quantity for 05 years	Unit of Measure	Local Bidders Unit Price in LKR (including NBT and excluding VAT)	Foreign Bidders Unit price foreign currency CFR- Colombo Price	Payment Term (A minimum credit period of 30 days (from the date received) is required for all invoices, covering 100% of the payment.)	Lead Time (Production + Delivery)	Remarks
1	Dessert Fork		144,000	Each					
2	Dessert Spoon		66,000	Each					
3	Teaspoon		54,000	Each					
4	Table Knife		144,000	Each					

Signature:..... [Signature of person signing the Bid]

Designation:..... [Designation of person signing the Bid with frank]

Date: [Insert date]

THIS IS A COMPULSORY FORM. IF THIS FORM IS NOT FILLED AND SUBMITTED, THE BID SHALL BE REJECTED.

ANNEXURE B - Technical/General Specifications & Compliance form (EY Cutlery)

Running Number	Technical Specifications (Mandatory)	Bidder's Response (Yes/No)	Remarks
1	<p>Fork</p> <p>*The fork tines should be square ended *Handle should be blunt-ended and non-detachable</p> <p>Knife Blade- *Should be round ended *Should have light serration Handle *Should be blunt-ended and non-detachable *In general, the knife should not have any sharp edges</p> <p>Dessert Spoon *Handle should be blunt ended and non-detachable</p>		
2	Material -18/0 Stainless Steel		
3	Design -As per the attached artwork (Attached below)		
4	Length: Fork – 166 mm (±5mm) Knife – 166 mm (±5mm) Dessert Spoon –152 mm (±5mm)		
5	Weight: Fork – 22g (±2g) Knife – 36g (±3g) Dessert Spoon – 24g (±2g)		
6	Finish - Should be fine and suitable for on board use		
7	Polishing Method: Mirror polish		
8	Washing Method: Please specify (If applicable)		
9	Branding: Logo and the words "SriLankan Airlines" to be etched on the handle. (refer artwork attached)		
10	Service Life: Please mention the average number of cycles the items can be reused		

Running Number	Technical Specifications (Mandatory)	Bidder's Response (Yes/No)	Remarks
1	<p>Packing:</p> <p>*Each cutlery item should be individually packed in a poly bag</p> <p>*300 individually packed pieces per carton - If differ, please specify</p> <p>*Cartons should be suitable for sea freighting/air freighting</p> <p>*Each shipment to be packed in wooden shipping crates.</p>		
2	<p>Printing:</p> <p>*Item code, quantity per carton to be printed on each carton.</p> <p>*Item code to be printed on each wooden crate.</p>		
3	<p>Lead time:</p> <p>Please indicate your production and delivery lead-time in the offer.</p>		
4	<p>Delivery:</p> <p>Staggered over the contract period</p>		
5	<p>Payment Terms:</p> <p>A minimum credit period of 30 days (from the date received) is required for all invoices, covering 100% of the payment.</p>		
6	<p>Termination Clause:</p> <p>The contract shall be awarded for a period of five (5) years.</p> <p>However, the Purchaser reserves the right to amend, reduce, or terminate the contract period in the event of persistent quality issues or recurrent delays in supply or service delivery.</p> <p>Such action may be taken at the sole discretion of the Purchaser, based on documented performance concerns, with a thirty (30) day notice period for termination.</p>		
7	<p>Agreeable to provide the Performance Bond</p> <p>10% of the total contract value</p>		

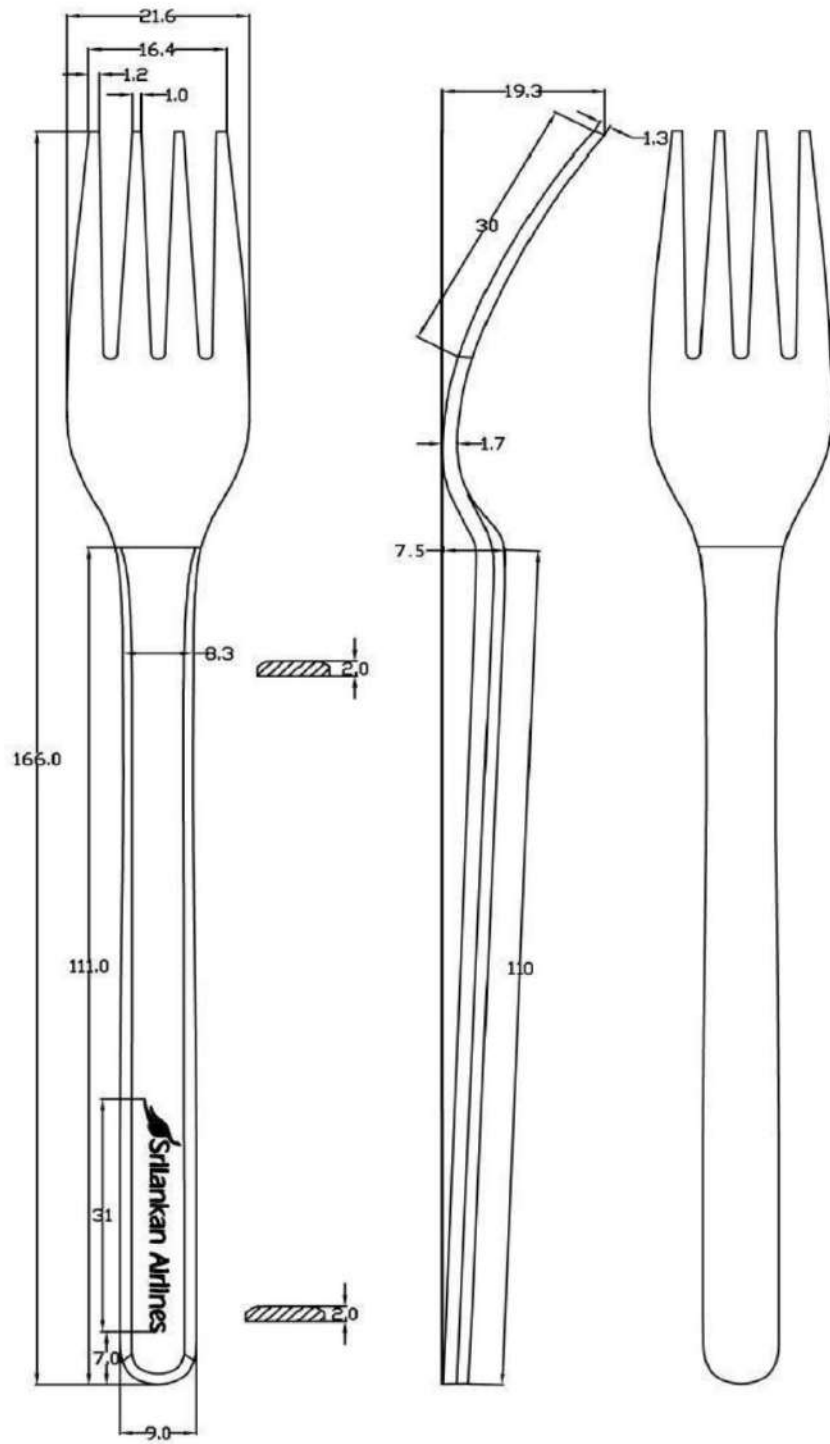

- All measurements are in mm (Millimeters)

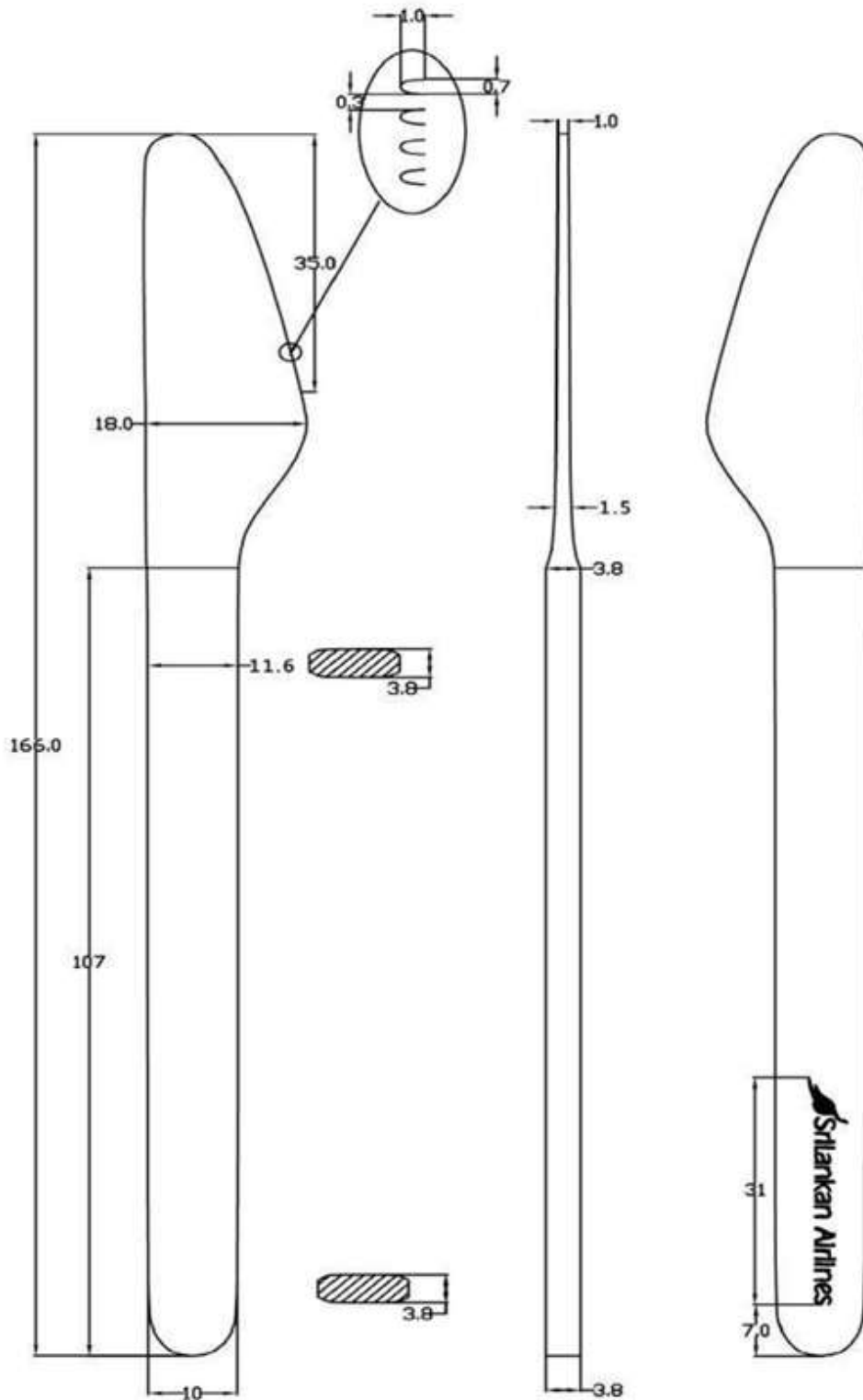

- All measurements are in mm (Millimeters)

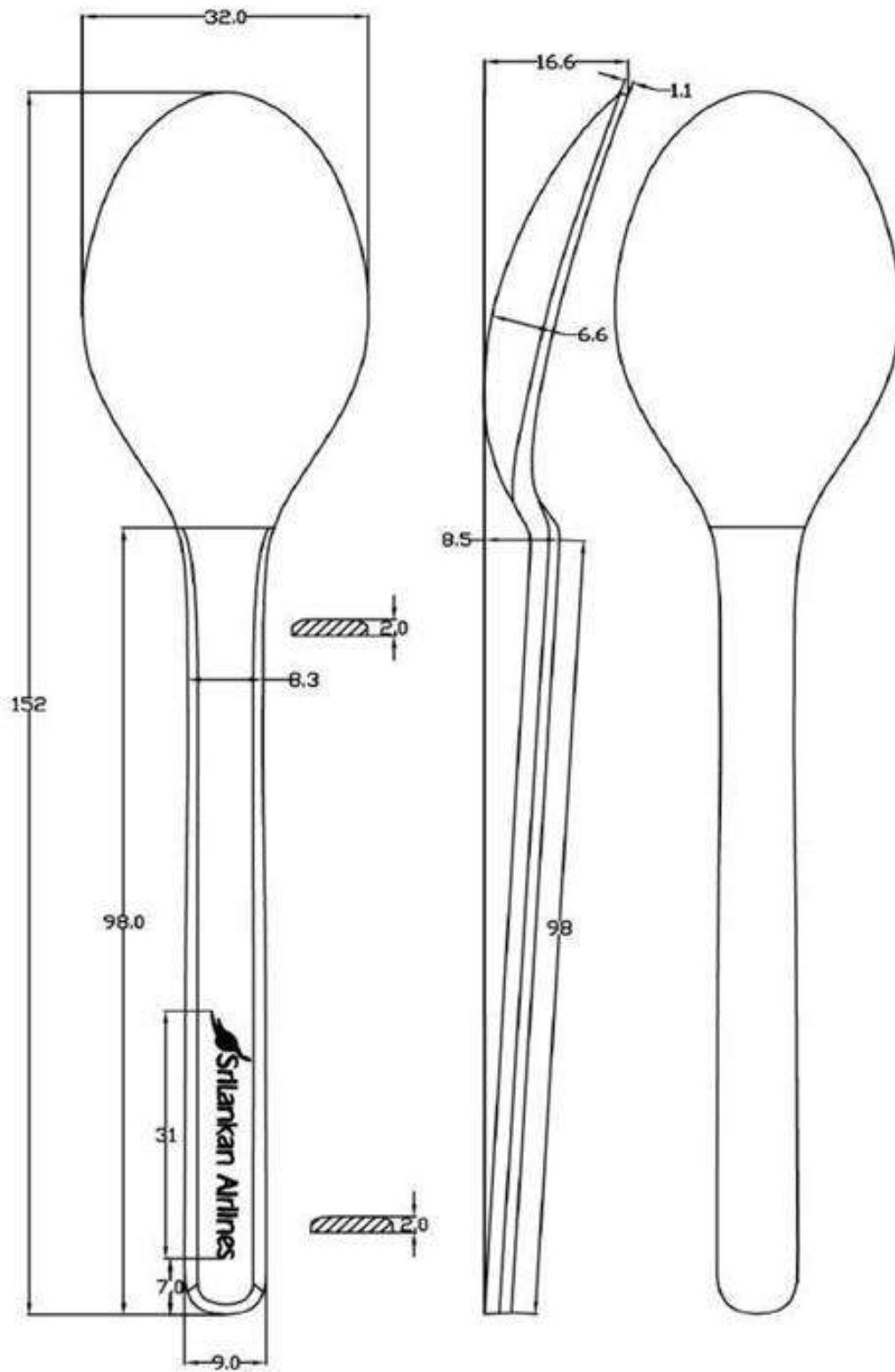

- All measurements are in mm (Millimeters)

THIS IS A COMPULSORY FORM. IF THIS FORM IS NOT FILLED AND SUBMITTED, THE BID SHALL BE REJECTED.

ANNEXURE C: Price Schedule Form (EY Cutlery)

Name of the Bidder (Commercial and the Registered name) :

Name of the Principal/ Manufacturer (Commercial and the Registered name) :

Line Item N°	Description of Goods	Country of Origin/ manufacture	Estimated Quantity for 05 years	Unit of Measure	Local Bidders Unit Price in LKR (including NBT and excluding VAT)	Foreign Bidders Unit price foreign currency CFR- Colombo Price	Payment Term (A minimum credit period of 30 days (from the date received) is required for all invoices, covering 100% of the payment)	Lead Time (Production + Delivery)	Remarks
1	EY Fork		660,000	Each					
2	EY Knife		840,000	Each					
3	EY Dessert Spoon		660,000	Each					

Signature:..... [Signature of person signing the Bid]

Designation:..... [Designation of person signing the Bid with frank]

Date: [Insert date]

THIS IS A COMPULSORY FORM. IF THIS FORM IS NOT FILLED AND SUBMITTED, THE BID SHALL BE REJECTED.

ANNEXURE D: Bid Securing Declaration

[Note: the purchaser is required to fill the information marked as “” and delete this note prior to the selling of the bidding document]*

*[The **Bidder** shall fill in this form in accordance with the instructions indicated in brackets]*

Date: -----*[insert date by bidder]*

Name of contract –[insert name]*

Invitation for Bid No: -----[insert number]*

To: -----[insert the name of the Purchaser]*

We, the undersigned, declare that;

1. We understand that, according to instructions to bidders (hereinafter “the ITB”), bids must be supported by a bid-securing declaration;
2. We accept that we shall be suspended from being eligible for contract award in any contract where bids have being invited by SriLankan Airlines, for the period of five years starting on the latest date set for closing of bids of this bid, if we;
 - (a) withdraw our Bid during the period of bid validity period specified; or
 - (b) do not accept the correction of errors in accordance with the Instructions to Bidders of the Bidding Document; or
 - (c) having been notified of the acceptance of our Bid by you, during the period of bid validity,
 - (i) fail or refuse to execute the Contract Form, if required, or
 - (ii) fail or refuse to furnish the performance security, in accordance with the ITB.
3. We understand this bid securing declaration shall expire if we are not the successful bidder, upon the earlier of (i) our receipt of a copy of your notification to the Bidder that the bidder was unsuccessful; or (ii) twenty-eight days after the expiration of our bid.
4. We understand that if we are a JV, the Bid Securing Declaration must be in the name of JV that submits the bid. If the JV has not been legally constituted at the time of bidding, the Bid Securing Declaration shall be in the names of all future partners as named in the letter of intent.

Signed [insert signature(s) of authorized representative] In the Capacity of [insert title]

Name [insert printed or typed name]

Duly authorized to sign the bid for and on behalf of [insert authorizing entity]

Dated on [insert day] day of [insert month], [insert year]

ANNEXURE E: Performance Bond

[The issuing agency, as requested by the successful Bidder, shall fill in this form in accordance with the instructions indicated]

-----[Issuing Agency's Name, and Address of Issuing Branch or Office] -----

Beneficiary: SriLankan Airlines Limited, Airline Centre, Bandaranaike International Airport, Katunayake, Sri Lanka

Date: -----

PERFORMANCE GUARANTEE No: -----

We have been informed that -----[name of Bidder](hereinafter called "the Bidder") has entered into Contract No. -----[reference number of the contract] dated ----- with you, for the -----Supply of - -----[name of contract and brief description] (hereinafter called "the Contract").

Furthermore, we understand that, according to the conditions of the Contract, a performance guarantee is required.

At the request of the Bidder, we -----[name of Agency] hereby irrevocably undertake to pay you any sum or sums not exceeding in total an amount of -----[amount in figures](------) [amount in words], such sum being payable in the types and proportions of currencies in which the Contract Price is payable, upon receipt by us of your first demand in writing accompanied by a written statement stating that the Contractor is in breach of its obligation(s) under the Contract, without your needing to prove or to show grounds for your demand or the sum specified therein.

This guarantee shall expire, no later than the --- day of ----,20..[insert date,28 days beyond the scheduled completion date including the warranty period] and any demand for payment under it must be received by us at this office on or before that date.

[signature(s)]

THIS IS A COMPULSORY FORM. IF THIS FORM IS NOT FILLED AND SUBMITTED, THE BID SHALL BE REJECTED.

ANNEXURE F: Non-collusion Declaration

I, the undersigned bidder/ bidder's representative/ bidder's agent, honestly, truthfully and solemnly declare that;

- (a) I, nor any other member, agent or representative of the firm/ company/ corporation/ partnership/ sole proprietorship that I represent, have entered into any combination, collusion or similar agreement with any person in connection with the prices to be submitted by any person with respect to the invitation for bid;
- (b) I, nor any person who represents me have acted to prevent any person from submitting a bid or to induce any person to refrain from submitting a bid in connection with the intention for bid (Bid No.);
- (c) This bid is not submitted in collusion with any other bid and is not made pursuant to any agreement, understanding or association with any other person in relation to such bid.

I declare that I have not received and will not accept any discount, fee, reward, commission or anything of value, directly or indirectly, from any person, company or corporation in connection with the submission of this bid.

I further declare that I have not given and will not give any discount, fee, reward, commission or anything of value, directly or indirectly, to any person, company or corporation in connection with the submission of this bid.

I, taking full responsibility for ensuring the absence of collusion, hereby pledge to abide by fair and ethical competitive practices throughout the entire procurement process and to fully comply with the relevant Procurement Guidelines issued by the National Procurement Commission.

I hereby declare that all the statements made by me above are true and correct.

.....
Signature of the Declarant

ANNEXURE G: Clientele Information Form

Company Name	Company Representative's Contact Details (Please state name, official email address and telephone number)	Client since	Products procured
1			
2			
3			
4			
5			
6			
7			
8			
9			
10			
11			
12			
13			
14			
15			

Annexure H: Sample Contract

This information is provided for sample reference only. Final contract terms, including pricing and applicable taxes, may vary.

The Agreement for Provision of Goods (hereinafter referred to as "Agreement") is made and entered into on this ____ day of ____ 2026

Between;

SRILANKAN AIRLINES LIMITED a company incorporated in Sri Lanka (Company Registration PB 67) and having its registered office at "Airline Centre", Bandaranaike International Airport, Katunayake, Sri Lanka, (hereinafter called and referred to as "SriLankan Airlines" which term or expression shall where the context so requires or admits mean and include the said SriLankan Airlines Limited, its successors, assignees and representatives) of the One Part;

And

_____ a company incorporated in _____ (Company Registration No. _____) and having its registered office at _____ (hereinafter called and referred to as the "Contractor" which term or expression shall where the context so requires or admits mean and include the said _____ its successors, assignees and representatives) of the Other Part.

WHEREAS SriLankan Airlines is desirous of procuring _____ on board the SriLankan Airlines flights (hereinafter referred to as "Goods") as per the specifications and estimated quantities provided in Schedules attached herewith to the Agreement.

WHEREAS the Contractor is engaged in supply of _____ and desirous of supplying the Goods to SriLankan Airlines on a non-exclusive basis according to the specifications and estimated quantities mentioned herein and communicated by SriLankan Airlines from time to time in the future;

WHEREAS the Contractor has expressed its offer to provide SriLankan Airlines with the Goods according to the terms and conditions provided herein and which offer has been accepted by SriLankan Airlines;

WHEREAS prior to the said offer and the execution of the Agreement, the Contractor has been apprised of the requirements and specification required by SriLankan Airlines for the supply and delivery of Goods and to all other matters which might have influenced the Contractor in making its Tender and has agreed to supply and deliver the Goods to SriLankan Airlines pursuant to the said requirements and specifications set forth in the Tender;

WHEREAS the Contractor has expressed its desire to provide SriLankan Airlines with Goods according to the terms and conditions provided herein.

IT IS HEREBY AGREED BY AND BETWEEN THE PARTIES AS FOLLOWS:

1. OBLIGATIONS OF THE CONTRACTOR:

1.1 The Contractor shall:

- 1.1.1 Deliver Goods as more fully described in the Schedule A in quantities ordered by SriLankan Airlines from time to time, to the locations more fully described in Schedule B hereto according to the specifications provided in Annex A (such schedules and annexes to be part and parcel of this Agreement) on non-exclusive basis on the terms and conditions set out herein.
- 1.1.2 Be deemed to have appraised itself fully of the provisions of this Agreement.
- 1.1.3 Ensure that Goods provided under this Agreement shall:
 - a) be in accordance with the specifications set out in Annex A;
 - b) conform with any sample provided by the Contractor during the selection process or thereafter and approved by SriLankan Airlines;
 - c) be fit for the purposes envisaged under this Agreement and suitable for consumption;

- d) meet hygiene and food safety standard specified by IFSA/AEA World Food Safety Guideline and/or ICQA Food Processing Safety Standards;
- 1.1.4 Ensure that it has the necessary/required licenses, approvals and authorizations to provide Goods to SriLankan Airlines envisaged under this Agreement.
- 1.1.5 Deliver the Goods on CFR-CMB basis (defined as per INCOTERMS latest version) to the locations set out in Schedule B in quantities mentioned in the relevant purchase order/releases within 80 days of the date of the order confirmation by SriLankan Airlines. The Contractor shall be responsible for providing all transportation necessary for the safe movement of Goods to the locations as specified in Schedule B of the Agreement.
- 1.1.6 If required by SriLankan Airlines, accept ad-hoc orders to supply Goods to SriLankan Airlines in additional quantities and additional orders for Juices for on board use which are recognised in this Agreement subject to availability and adequate lead time. Where an additional order is placed for juices for on board use which are recognised in this Agreement, the Contractor shall make available the additional quantities and additional orders at the rates stipulated in Schedule C.
- 1.1.7 At its own cost comply with all requirements of any Governmental or local Governmental regulations (particularly with those pertaining to Board of Investment of Sri Lanka, Customs in Sri Lanka or any other country, safety, health, labour, clearing and security) and shall indemnify and hold harmless SriLankan Airlines against any loss, damage or claim that may arise due to the non-compliance with any such regulations.
- 1.1.8 Invoice SriLankan Airlines for the Goods at the rates and in the manner specified and described herein (particularly as set out in Clause 3 and Schedule C).
- 1.1.9 Not assign, transfer or sublet its rights or obligations under this Agreement without the prior written approval of SriLankan Airlines. Provided that the Contractor shall not be relieved of responsibility under this Agreement for such portion of its obligations as are assigned, transferred or sublet.
- 1.1.10 Not at any time, during or after the term of this Agreement, divulge or allow to be divulged to any person any confidential information relating to the business and operations of SriLankan Airlines unless duly authorized in writing by SriLankan Airlines or required under any law.
- 1.1.11 Pay liquidated damages as stipulated in Schedule C if the Contractor fails to deliver the Goods on time or SriLankan Airlines rejects the Goods pursuant to Clause 2.6 hereof.
- 1.1.12 Subject to the terms and conditions of this Agreement, the Goods shall be delivered on CFR-CMB (INCOTERMS latest version) and the rights and obligations of the Parties and the transfer of risk and title shall be governed in terms of CFR-CMB (INCOTERMS latest version).
- 1.2 In the event any of the Goods supplied or delivered pursuant to this Agreement are rejected by SriLankan Airlines, the Contractor shall take immediate steps, and not later than 15 working days from the rejected date to either replace the rejected Goods or make alternations necessary to meet the specifications, free of any costs to SriLankan Airlines.
- 1.3 In the event of any item of the Goods being damaged at any stage prior to the handing over of the Goods to nominated freight forwarder at the port of dispatch or if any item of the Goods are lost during transit from the Contractor's warehouse to the locations as set forth under Schedule B or if any item of the Goods are wrongly supplied, the Contractor shall replace the said damaged, lost or wrongly supplied item of Goods with new ones and shall ensure that supply and delivery of same is affected speedily and no later than Four (04) weeks from the date of notification by SriLankan Airlines ("Replacement") at its own cost. SriLankan Airlines shall not be liable for any damage or deterioration caused or occurring to the wrongly supplied items under Clause 1.3 while in the custody of SriLankan Airlines. In the event the Contractor fails to provide any of the item of Goods within a reasonable period of time, SriLankan Airlines shall be at liberty to purchase such items of Goods from another source and the Contractor shall reimburse SriLankan Airlines' for any cost incurred in respect of same.

2. RIGHTS AND OBLIGATIONS OF SRILANKAN AIRLINES:

- 2.1 SriLankan Airlines shall pay the Contractor for Goods provided at the rates and in the manner specified and described herein (particularly in Clause 3 and Schedule C hereto). For the avoidance of doubt, the adjustment/variation of the quantity of Goods provided under this Agreement shall still be provided by the Contractor in accordance to the same rates as specified under Schedule C.
- 2.2 SriLankan Airlines may vary the Goods specified in the specifications set out in Annex A hereto, giving sufficient lead time, with mutual agreement of the Contractor.
- 2.3 SriLankan Airlines shall have the right to charge liquidated damages against the Contractor as provided in Schedule C where the Contractor fails to deliver the Goods as required under this Agreement or any non-compliance or breach by the Contractor of any of its obligations under this Agreement.
- 2.4 Notwithstanding anything contained in this Agreement, SriLankan Airlines may at any time hire, purchase and/ or engage any other person(s)/contractor(s) to purchase goods which are similar to the Goods contemplated in this Agreement and/or which SriLankan Airlines may deem in its opinion as specialized in nature.
- 2.5 Have the right to inspect and reject the Goods (or any part thereof) provided under this Agreement if in its opinion it decides that such Goods (or any part thereof) fail to meet the specifications required by SriLankan Airlines under this Agreement or is not of merchantable quality and unfit for the purposes intended. SriLankan Airlines right to inspect and where necessary, reject the Goods (or part thereof) after the Goods' arrival or issuance of the Delivery Note shall in no way be limited or waived by reason of the Goods having previously been inspected and passed by SriLankan Airlines or its representative prior to the Goods delivery.
- 2.5 When the Goods are received at the locations as specified in Schedule B, SriLankan Airlines shall conduct a quality and quantity inspection of the same and shall accept the Goods at the locations. If there is a discrepancy in qty received and qty indicated in invoice, UL will inform same to vendor within 3 working days of receipt of shipment to stores.
- 2.6 Upon the acceptance of the Goods by SriLankan Airlines, the Goods shall become and remain the property of SriLankan Airlines. Notwithstanding that title in whole or in part of the Goods may have passed to SriLankan Airlines pursuant to Clause 2.7, the Contractor shall remain and be responsible to SriLankan Airlines to make good any loss or damage to such Goods due to any act or negligence on the part of the Contractor or Contractor's Representatives; or arising from any incident whatsoever from the commencement of this Agreement until the Goods are handed over to SriLankan Airlines at the port of destination, Colombo and accepted by SriLankan Airlines.
- 2.7 Nothing in this Agreement shall prevent SriLankan Airlines from sourcing similar Goods or any Juices for on board use from any third party on whatsoever basis during the period of the Agreement.
- 2.9 In the event SriLankan Airlines in its opinion decide that the Goods are not in accordance to the requirements and specifications set forth under this Agreement, SriLankan Airlines shall have the right to reject the Goods and:
- (i) refrain from making any payments pursuant to such Order made in respect of such Goods; and
 - (ii) either replace the rejected Goods with goods meeting the specifications required under this Agreement free of any costs to SriLankan Airlines; or
 - (iii) obtain substitute goods for the rejected Goods and the Contractor shall reimburse to SriLankan Airlines all costs incurred by SriLankan Airlines in respect of same.

3. INVOICING & PAYMENT:

- 3.1 The Contractor shall provide the Goods at the rates assigned to each category as described in Schedule C hereto.

- 3.2 The Contractor shall not increase the rates, charges or any other prices set out in this Agreement during the period of this Agreement.
- 3.3 Subject to Clause 3.5, SriLankan Airlines will settle all invoices submitted by the Contractor for Goods under this Agreement within 90 days from the date of shipping. The invoice will be raised at the time of departure of the Goods from the warehouse of the Contractor. A copy of invoice will be emailed to SriLankan Airlines at the time, the invoice is raised.
- 3.4 SriLankan Airlines shall inform any dispute on any invoice within 10 days of receipt of the invoice from the Contractor and proceed to settle the undisputed amount within the payment period referred to in Clause 3.3 hereof. The Parties shall endeavour to resolve the dispute on the invoice amicably within 30 days of notification or any other period mutually agreed and where the Parties fail to resolve the dispute amicably, Parties shall resort to the dispute resolution mechanism provided in this Agreement as a mean to resolve the dispute. If the dispute is resolved in the Contractor's favour, the amount payable to the Contractor shall be payable within fourteen (14) days of the resolution of the dispute.
- 3.5 SriLankan Airlines shall be entitled to withhold any payments due to the Contractor under this Agreement and any sums of money required to be withheld by SriLankan Airlines under any law or regulation for the time being in force and/or pursuant to this Agreement.
- 3.6 Payment shall be made in accordance to the payment details provided in Schedule C.
- 3.7 Invoices to be addressed to: Manager Financial Services, SriLankan Airlines Ltd, Airlines Centre, BIA, Katunayake, Sri Lanka and/or email to: swarna.liyanage@srilankan.com

4. LIABILITY & INDEMNITY:

- 4.1 The Contractor shall indemnify and hold harmless SriLankan Airlines free and clear from and against any and all losses, costs, expenses, claims, damages and liabilities, to SriLankan Airlines, its officers, agents, employees, representatives or any third parties and/or any property, that may arise pursuant to this Agreement, in particular pursuant to (but not limited to) any:
- a) claim in respect of any workers of the Contractor under the Workman's Compensation laws or any other law;
 - b) accident, injury or death caused to any person by negligence or wilful misconduct of the Contractor, its servants, agents employees or representatives;
 - c) acts of theft, pilferage, damage of property caused by the Contractor or its servants, agents employees or representatives;
 - d) if the Goods provided to SriLankan Airlines are not suitable for the use intended and/or does not meet the specifications set out in this Agreement including alleged illness, injury, death or damage as a result of the use of any the Goods produced, packaged, stored or shipped by Contractor; provided, however, that the Contractor shall not be responsible for, and shall not be required to provide indemnification against, any liability for illness, injury, death or damage attributable to defects in Goods that independent investigation discloses originated solely after the Goods left the custody and control of Contractor and was not attributable to any act or omission of Contractor prior to such Goods leaving such custody and control;
 - e) violation of any laws, regulations or intellectual property rights of any party;
 - f) breach of any obligations, representations, warranties or covenants in the Agreement by the Contractor;

- 4.2 SriLankan Airlines shall indemnify and hold harmless the Contractor free and clear from and against any and all losses, costs, expenses, claims, damages and liabilities that may arise pursuant to the death or injury of a worker of the Contractor or damage to the Contractor's (or its workers) property caused by SriLankan Airlines' negligence or wilful misconduct.
5. INSURANCE:
- 5.1 The Contractor shall, without prejudice to its obligations under Clause 5.1 and as a condition precedent to this Agreement, at its own cost secure policies of insurance as described below, acceptable to SriLankan Airlines which shall be kept current throughout the term of this Agreement. These insurances will include but not limited to;
- a) Commercial general liability insurance policy including product liability with a limit of indemnity of not less than USD 500,000 any one incident. The policy shall cover third party (including employees of SriLankan Airlines) for injury / death and/or property damage caused by the Contractor or their representatives and shall include liability for any injury /death to persons (including passengers) using or consuming the products / services offered by the Contractor in the performance of this contract.
 - b) Workmen's Compensation Insurance or employer's liability insurance for all employees of the contractor or their representatives involved with performance of this contract. The policy shall include extensions for riot and terrorism.
- 5.2 Such insurances as aforementioned incorporate the following provisions in respect of liability assumed by the Contractor under this Agreement (unless otherwise specified by SriLankan Airlines):
- a) Name SriLankan Airlines, its successors and assigns, directors, officers, servants, employees, agents and contractors as additional assureds.
 - b) A severability of interest clause, where the insurances (except with regard to the limits of liability) will operate in all respects as if there were a separate policy covering each assured.
 - c) Confirm that such insurances shall be primary without right of contribution from any other insurance carried by SriLankan Airlines.
 - d) Provide that the cover afforded to SriLankan Airlines shall not be invalidated by act or omission by the Contractor or by any other person and shall remain valid regardless of any breach or violation by the Contractor or any other person of any warranty, declaration or condition contained in such insurances.
 - e) The Insurer (of the insurances) will provide 15 days prior written notice to SriLankan Airlines of any material change of the insurances affected pursuant to this Clause.
- 5.3 The Contractor shall also within 15 days of the execution of this Agreement and at each consequent renewal (or renewal of insurances whichever shall occur first) produce an Insurance Policy/Certificate/Endorsement evidencing coverage as per the requirements of Clause 5.1.
- 5.4 In the event the Contractor defaults and/or fails to comply with any of its obligations under this Clause, SriLankan Airlines may (without prejudice to any other remedy available under this Agreement) pay any premiums that may remain due and unpaid provided that SriLankan Airlines shall be entitled to deduct or charge the Contractor any such amounts expended by it to pay such aforementioned unpaid premiums.
- 5.5 The insurance coverage required by Clause 5.1 and 5.2 shall at all times be valid and adequate to meet all the obligations set out above and any other obligations required by law. Failure to maintain insurance coverage to the required level will be considered by SriLankan Airlines as a fundamental breach of this Agreement.

6. NON-COMPLIANCE:

- 6.1 In the event of the non-compliance or breach by the Contractor of any of its obligations contained in this Agreement, SriLankan Airlines may at its discretion, without prejudice to any of its rights under this Agreement:
- a) Terminate this Agreement as per Clause 7 below:
 - b) Charge the Contractor liquidated damages at the rate specified in Schedule C of the estimated amount of the monies payable for the relevant Goods for the relevant period of non-compliance or breach; and/or
 - c) Obtain the Goods from another contractor provided however, that in the event any money is expended by SriLankan Airlines on account of the Contractor's non-compliance or breach of its duties, such said expenditure shall be re-charged to the Contractor.

The Contractor shall in the aforementioned instances make good the irregularity, breach and/or lapse as soon as possible to the satisfaction of SriLankan Airlines and shall reimburse SriLankan Airlines any expenses incurred by it in such said instances.

7. TERM & TERMINATION:

- 7.1 This Agreement shall be valid for a period of 05 years commencing from ____ 2026 until ____ unless terminated earlier and shall automatically stand terminated upon the expiry of the Agreement. Notwithstanding the above, the Parties may extend the Term of this Agreement upon the expiry of the Term for a further period of 1 year by written mutual agreement on the same terms and conditions of this Agreement; provided however that such extension shall be subject to the Contractor's satisfactory performance of the Agreement decided at the sole discretion of SriLankan Airlines.
- 7.2 Notwithstanding Clause 7.1, SriLankan Airlines may terminate this Agreement at any time, without assigning any reasons whatsoever, by giving the Contractor 90 days' written notice of termination without any liability to pay compensation and such termination shall take effect on the expiry of the said 90 days' notice period.
- 7.3 SriLankan Airlines may terminate this Agreement forthwith in writing in the event the Contractor does not:
- a) provide the Goods at the time, manner and/or to the specifications/ quality required by SriLankan Airlines pursuant to this Agreement;
 - b) comply with the requirements and/or notices of SriLankan Airlines; and/or
 - c) perform, fails or is failing in the performance of any of its obligations under this Agreement.
- 7.4 Subject to Clause 7.3 hereof, either party shall have the right to terminate this Agreement forthwith at any time by giving written notice to the other upon the happening of any of the following events:
- a) if the other party is in breach of any of the terms or conditions of this Agreement and fails to rectify same within 30 days of the written notice of the breach to the defaulting party or immediately if the breach is incapable of remedy;
 - b) if the other party enters into liquidation whether compulsory or voluntary (otherwise than for the purpose of amalgamation or reconstruction) or compounds with or enters into a scheme of arrangement for the benefit of its creditors or has a receiver appointed of all or any part of its assets or takes or suffers any similar action in consequence of debt; and/or
 - d) if the other party shall cease substantially to carry on trade or shall threaten to cease substantially to carry on trade.

- e) disruption to the performance of the Agreement for a period of more than 60 days due to force majeure event.
- 7.5 Expiration or termination of this Agreement pursuant to the provisions of this Clause shall be without prejudice to the accrued rights and liabilities of either party.
- 7.6 On termination of this Agreement the Contractor shall only be entitled to receive the payment of monies (less any monies as SriLankan Airlines is entitled to deduct/set-off under this Agreement) for Goods duly provided in accordance with the terms of this Agreement. The Contractor shall not be entitled to any further costs, remuneration consequential or special damages, loss of profits or revenue claimed to have been suffered by the Contractor (including its agents, employees and representatives) as a result of this Agreement.
- 7.7 In the event SriLankan Airlines terminates this Agreement in whole or in part, pursuant to 7.3 a), b) or c) of the Agreement, SriLankan Airlines may procure upon such terms and in such manner as it deems appropriate, goods, as the case may be, similar to those undelivered under the Agreement, and the Contractor shall be liable to SriLankan Airlines for any excess costs for such similar goods procured by SriLankan Airlines. However, the Contractor shall continue performance of the Agreement to the extent not terminated herein.
8. BANK GUARANTEE:
- 8.1 Upon the execution of this Agreement, the Contractor shall furnish SriLankan Airlines a bank guarantee for the sum as set forth under Clause 2.1 of Schedule C, as an irrevocable and unconditional bank guarantee drawable on demand in Sri Lanka from a bank acceptable to SriLankan Airlines, in a form and substance satisfactory to SriLankan Airlines as security for the due and proper performance by the Contractor of its obligations under this Agreement. All applicable bank charges (including any charges at the time of encashment) on such bank guarantee shall be borne by the Contractor). The said bank guarantee shall remain in force for the duration of this Agreement and 90 days thereafter.
- 8.2 The proceeds of the Bank Guarantee shall be payable to SriLankan Airlines as compensation for any loss resulting from the Contractor's failure to complete its obligations under the Agreement.
- 8.3 The Bank Guarantee will be discharged by SriLankan Airlines and returned to the Contractor within 90 days of the expiry of this Agreement or within 90 days following the date of completion of Contractor's obligations under the Agreement, whichever is later, less monies due to SriLankan Airlines and/or as SriLankan Airlines is entitled to deduct/set-off under this Agreement.
- 8.4 In the event, that the Contractor fails to pay any monies due to SriLankan Airlines (or any part thereof) as and when the same become payable under this Agreement, SriLankan Airlines shall be entitled to adjust or deduct any monies due to SriLankan Airlines from the Bank Guarantee accordingly. In the event of an adjustment or deduction of the Bank Guarantee by SriLankan Airlines against any sums due from the Contractor, the Contractor shall immediately submit to SriLankan Airlines the amount adjusted or deducted by SriLankan Airlines and restore the Bank Guarantee to its original amount.
- 8.5 SriLankan Airlines shall not make any payments under this Agreement to the Contractor until SriLankan Airlines has received the Bank Guarantee as stipulated under Clause 8 hereof.
- 8.6 SriLankan Airlines' rights with respect to the Bank Guarantee shall be in addition to any other rights or remedies available to SriLankan Airlines.
9. GOVERNING LAW:
- 9.1 This Agreement shall be governed by the laws of Sri Lanka and subject to the jurisdiction of the courts in Sri Lanka.

10. FORCE MAJEURE:

- 10.1 In the event that either party shall be wholly or partly unable to carry out its obligations under this Agreement by reasons or causes beyond its control, including by way of illustration Acts of God or the public enemy, fire, floods, explosions, epidemics, insurrection, riots or other civil commotion, war, Government order or by any other cause (excluding, however, strikes, lockouts or other labour troubles), which it could not be reasonably be expected to foresee or avoid, then the performance of its obligations in so far as they are affected by such cause shall be excused during the continuance of any inability so caused. Such cause(s) shall however as far as possible be remedied by the affected party with all reasonable despatch.
- 10.2 Notwithstanding the above each party shall give the other as soon as possible notice of the occurrence or imminent occurrence of an event as indicated above and where such notice is given verbally it shall be followed immediately in writing.
- 10.3 In the event the force majeure event relates to delivery of Goods by the Contractor, unless otherwise directed by SriLankan Airlines in writing, the Contractor shall continue to perform its obligations under the Agreement as far as is reasonable and practical, and shall seek all reasonable alternative means for performance not prevented by the force majeure event. In case of delays in the completion of delivery in accordance to the time schedule as specified in the respective Purchase Order(s) due to any of the force majeure event mentioned above, the time schedule for the delivery of Goods shall be extended accordingly.

11. GENERAL:

- 11.1 This Agreement shall constitute the entire agreement and understanding of the parties and shall supersede all prior agreements, whether written or oral between the parties hereto concerning the subject matter hereof.
- 11.2 In the event of a conflict between this Agreement and its Schedules, the Schedules shall take precedence over this Agreement in respect of the subject matter thereof. In the event of a discrepancy between Purchase Order and the Agreement, the Purchase Order will take precedence over this Agreement in respect of the subject matter thereof.
- 11.3 In the event that either party shall be rendered wholly or partly unable to carry out its obligations under this Agreement as a result of strikes, lockouts and labour troubles, then such party so incapacitated shall compensate such other for damage and/or loss suffered by such other as a result of such strike, lockout or labour trouble.
- 11.4 At all times the Contractor (together with its workers) will be deemed to be an independent contractor and shall not under any circumstances be considered an employee, representative or agent of SriLankan Airlines.
- 11.5 The right and remedies of SriLankan Airlines against the Contractor for the breach of any condition and for obligations undertaken by the Contractor under this Agreement shall not be prejudiced or deemed to be waived by reason of any indulgence or forbearance of SriLankan Airlines.
- 11.6 Nothing in this Agreement shall prevent SriLankan Airlines from availing itself of any remedies provided under the general law in addition to the remedies stipulated in this Agreement.
- 11.7 Except to the extent as amended under the Purchase Order(s), this Agreement shall not be varied or modified otherwise than by an instrument in writing of even date herewith or subsequent hereto executed by or on behalf of SriLankan Airlines and the Contractor by its duly authorised representatives.
- 11.8 If any provision of this Agreement should become or be adjudged invalid or unenforceable for any reason whatsoever, such invalidity or unenforceability shall not affect any other part of this Agreement and all other provisions shall remain valid and in full force and effect.
- 11.9 The titles to the clauses in the Agreement are for convenience of reference only and do not form part of this Agreement and shall not in any way affect the interpretation thereof.

- 11.10 SriLankan Airlines does not grant the Contractor any right, title or interest in any of its designs, labels, know-how, trade names, trademarks, service marks, logos and other distinctive brand features or business identifiers, logo, copyright or any other intellectual property rights of SriLankan Airlines (“Intellectual Property Rights”) except as expressly authorised in writing by SriLankan Airlines and the Contractor shall not have any right, title or interest in the said Intellectual Property Rights of SriLankan Airlines other than the right to use it for purposes of this Agreement for the Term hereof only with the express written consent of the SriLankan Airlines.
- 11.11 The Contractor shall not issue any press release or other public announcement related to this Agreement, written or oral, without the prior written consent of SriLankan Airlines, except as required by law or a court order. For avoidance of any doubt, the Contractor shall not make, give or issue any press release or other press activity involving or referring to SriLankan Airlines or any of its affiliates or their services or operations, without SriLankan Airlines prior written approval.
- 11.12 The Contractor expressly assures and warrants that it has all the necessary approvals, authorizations and licenses to enter into this Agreement and to provide the Goods envisaged under this Agreement.
- 11.13 Any notice or other communication required or authorised by this Agreement to be served or given by either party to the other shall be deemed to have been duly served or given if in writing and
 - (a) left at or sent by prepaid registered post to the last known place of business of that; or
 - (b) sent by fax or e-mail to such place of business and confirmed by prepaid registered post, similarly addressed, within 24 hours of the despatch of such fax or e-mail.

In the case of SriLankan Airlines to -

SriLankan Airlines Limited
 Commercial Procurement,
 Bandaranaike International Airport,
 Katunayake
 Sri Lanka
 Fax : 01 9733 5225
 E-mail: wiranga.perera@srilankan.com / Srimal.kamalpriya@srilankan.com
 Attention: Mr. Wiranga Perera/ Mr. Srimal Gihan

In the case of the Contractor to -

IN WITNESS WHEREOF the parties hereto have caused their authorised signatories to place their hands hereunto and to one other of the same tenor on the date first referred to above in:

For and on behalf of
 SRILANKAN AIRLINES LIMITED

For and on behalf of

 Name:
 Designation:

 Name:
 Designation:

Witness:

Witness: _____

Name:
 Designation:

Name:
 Designation:

SCHEDULE A

1. Preliminary:

- 1.1 The specifications of Goods shall be deemed to form and be read and construed as an integral part of the Agreement.
- 1.2 If persons contracted by and on behalf of the Contractor require any security passes, clearances or other relevant documentation for the provision of Goods, the Contractor shall ensure that such passes clearances and documentation have been duly secured from the relevant parties/authorities in a timely manner.
- 1.3 Please refer Annex A attached for Specifications of the

2. Time Schedule:

- 2.1 The Contractor shall upon receipt of the Purchase Order successfully complete the supply and delivery of the Goods to the locations specified in Schedule B according to the time tables given by SriLankan Airlines as set forth under the Purchase Agreement, Purchase Order or Purchase release in accordance to the terms and conditions of the Agreement.

SCHEDULE B

(LOCATIONS)

1. Locations:

The Contractor shall supply and deliver the Goods on CFR-CMB basis (INCOTERMS latest version). Contractor will be responsible for the shipment till it reaches Colombo port.

2. Access to Locations:

- 2.1 Access to and from all premises of SriLankan Airlines will be subject to instructions and directions given by SriLankan Airlines and/or any other relevant party or authority.
- 2.2 The Contractor will ensure that workers contracted for and on behalf of the Contractor to provide the Goods under this Agreement shall under no circumstance violate Clause 2.1 above.
- 2.3 The Contractor shall indemnify SriLankan Airlines or any other party for death, injury, loss or damage in the event the Contractor or its workers for whatever reason are in breach of Clause 2.1 or any other stipulations under this Agreement.

SCHEDULE C
(RATES & CHARGES)

1. Rates

- 1.1 Rates payable by SriLankan Airlines to the Contractor in respect of the Goods specified under this Agreement will be as follows:
Please refer Annex B for details.
- 1.2 Notwithstanding Clause 1.1 in this Schedule, SriLankan Airlines shall be entitled to deduct from the aforementioned amounts payable by SriLankan for the delivery of the Goods any monies as may be deductible under this Agreement.

2. Bank Guarantee

- 2.1 Bank Guarantee / Security Deposit Amount shall be for a minimum amount of 5% of the agreement value as security to secure the due and proper performance by Contractor of its obligations inter alia under this Agreement.

3. Liquidated Damages

The Contractor shall pay liquidated damages as follows:

Incident	Liquidated Damages
Delayed delivery	If the Contractor delays the delivery of Goods for more than 10 days from original delivery date set forth in the Purchase Order, the Contractor shall pay 1% of the invoice value for each day of delay commencing from the delivery date up to a maximum of 30 delayed days.
Non-compliance or Breach of Agreement	If the event of any occurrence of any non-compliance of the requirements of this Agreement or breach of this Agreement, the Contractor will be charged _____ as liquidated damages not as a penalty for each occurrence of non-compliance by the Contractor of requirements under this Agreement or breach of this Agreement.

Notwithstanding Clause 3 of Schedule C above, SriLankan Airlines shall have the right of settling any other amounts as costs or damages arising from the Contractor's breach, non-performance or partial performance of its obligations under this Agreement.

ANNEX A
(SPECIFICATIONS)

ANNEX B

TYPE	ITEM	ESTIMATED QUANTITY	UNIT PRICE
GOODS			
TAXES			
TOTAL COST PAYABLE			

Payment Term:

Method of payment :

Bank details :

Head Office :

Account Name :

Period of Agreement : 05 years commencing from ___ until ___
Price shall be fixed for the Term of the Agreement

Annexure I: Vendor Information Form

VENDOR INFORMATION FORM

(To be filled by the vendor)

Section A – Basic information of the vendor	
1. Registered Name of the Vendor :	
2. Date of Incorporation:	
3. Country of Incorporation:	
4. Nature of business :	5. Company type :
6. Telephone & Fax numbers : Tel: _____ Fax: _____	7. E-mail address :
8. Registered address :	
9. Other contact details (if any) :	
10. Registered Name and address of local agent (if any)	
Section B – Details of Directors, Shareholders and related parties	
1. Name(s) of Directors	

2. Name(s) of Shareholders	
3. If the Shareholders are incorporated entities, please state the shareholders of such entities	
4. If the Shareholders are equity funds, please state the owners of such funds	
5. Name (s) of Directors of Parent/Subsidiary who are also Directors of SriLankan Airlines	
6. Name(s) of Directors of Parent/Subsidiary who are also Employees of SriLankan Airlines	
7. Names of Close Family Members who are either Directors/Employees of SriLankan Airlines	

***Please note that the copies of passports and proof of residence of the above mentioned Shareholders / Directors / Owners of funds shall be submitted by the vendor upon the request of SriLankan Airlines.**

As the authorized representative of [name of the Vendor], I hereby confirm on behalf of[name of the Vendor] that the information provided above are true and accurate and acknowledge that the bid of[name of the Vendor] submitted herewith shall be rejected in the event all or any of the information submitted above is found to nbe incorrect.

Details of vendor’s authorized signatory:

Name:

Designation:

Date:

Signature & Company Rubber Stamp:

Section C - Business verification : Duly signed and stamped copy of above document to be supported by the following documents

✓ Tick the appropriate boxes

- | | |
|--|--|
| <input type="checkbox"/> A copy of the Certificate of Incorporation certified by the Company Secretary of the vendor Company | <input type="checkbox"/> A copy of Form 15 (Sri Lankan Companies) certified by the Company Secretary or a letter from the Company Secretary confirming the shareholding. |
| <input type="checkbox"/> A copy of Form 20 (Sri Lankan Companies) certified by the Company Secretary or a letter from the Company Secretary confirming the directors | <input type="checkbox"/> For Partnerships, list of partners confirmed by one of the partners, preferably by the most senior partner. |
| <input type="checkbox"/> For partnerships and sole proprietorships, certificate of business registration | <input type="checkbox"/> Audited financial statements of the vendor Company for the last three years |
| | <input type="checkbox"/> Others (specify) |